



Radioactive Wastes in the UK:

A Summary of the 2007 Inventory

Introduction

The UK Government's Department for Environment, Food and Rural Affairs (Defra) and the Nuclear Decommissioning Authority (NDA) periodically publish an inventory of radioactive waste in the UK. This inventory provides a reference source of information for Government and its agencies, and others with a role or interest in the management of radioactive waste.

This booklet summarises the 2007 UK Radioactive Waste Inventory, which is the latest public record of information on the sources, quantities and properties of Low Level Waste (LLW), Intermediate Level Waste (ILW) and High Level Waste (HLW) in the UK. The 2007 Inventory contains details of over one thousand individual wastes that have been reported by organisations responsible for their management.

Glossary

Committee on Radioactive Waste Management

The Committee on Radioactive Waste Management (CoRWM) is an independent body set up by Government to recommend a strategy for the long-term management of higher activity wastes in the UK. The Committee reported in July 2006. CoRWM has been re-constituted with modified terms of reference and membership to scrutinise the Managing Radioactive Waste Safely (MRWS) programme and its implementation.

Defra

The UK Government department which, with the environment departments of Wales, Scotland and Northern Ireland, sets policy for UK radioactive waste management.

Disposal

The emplacement of waste in a suitable facility without intent to retrieve it. (Retrieval may be possible but, if intended, the appropriate term is storage.)

Geological disposal

Geological disposal usually refers to a long-term management option involving the emplacement of radioactive waste in an engineered repository at between 200 metres and one kilometre underground where the geology (rock structure) provides a barrier against the escape of radioactivity.

Low Level Waste Repository

The Low Level Waste Repository (LLWR) near the village of Drigg, south of Sellafield, in Cumbria has operated as a national disposal facility for LLW since 1959.

Managing Radioactive Waste Safely

The Managing Radioactive Waste Safely (MRWS) programme was established by the UK Government and the Devolved Administrations for Scotland, Wales and Northern Ireland for developing and implementing a policy for managing the UK's higher activity wastes in the long-term.

NDA

A public body set up by the Government in April 2005 with responsibility for the UK's public sector civil nuclear liabilities, and their subsequent management. In October 2006, the Government also gave the NDA the responsibility for developing and ensuring delivery and implementation of the programmes for interim storage and geological disposal of the UK's higher activity wastes. From March 2007, the NDA was also given responsibility for developing a UK wide strategy for managing the UK nuclear industry's LLW and for securing disposal capacity for LLW generated by non-nuclear industry users.

Nuclear fuel

Fuel used in a nuclear reactor. Most fuel is made of uranium, and produces heat when the uranium atoms split into smaller fragments.

Plutonium

A radioactive element created in nuclear reactors. It can be separated from spent nuclear fuel by reprocessing. Plutonium is used as a nuclear fuel, in nuclear weapons and as a power source for space probes.

Radioactivity

A property possessed by some atoms that split spontaneously, with release of energy through emission of a sub-atomic particle and/or radiation.

Reprocessing

The chemical extraction of reusable uranium and plutonium from waste materials in spent nuclear fuel.

Storage

The emplacement of waste in a suitable facility with the intent to retrieve it at a later date.

Uranium

A radioactive element that occurs in nature. Uranium is used for nuclear fuel and in nuclear weapons.

What is radioactive waste?

Material that has no further use and is above a certain level of radioactivity is known as radioactive waste. Radioactive waste can harm people and the environment, and so is carefully controlled.

Radioactive waste is divided into three main categories according to how much radioactivity it contains and the heat that this radioactivity produces (see below).

Low Level Waste (LLW)

Wastes not exceeding specified levels of radioactivity.

Overall, the major components of LLW are building rubble, soil and steel items such as framework, pipework and reinforcement from the dismantling and demolition of nuclear reactors and other nuclear facilities and the clean up of nuclear sites. However, at the present time most LLW is from the operation of nuclear facilities, and this is mainly paper, plastics and scrap metal items.

A sub-category of LLW is Very Low Level Waste (VLLW). This comprises small volumes principally from hospitals and universities that can be safely disposed of with municipal, commercial or industrial waste (either directly or after incineration), and larger volumes from nuclear sites that can be disposed of to specified landfill facilities.

Intermediate Level Waste (ILW)

Wastes exceeding the upper boundaries for LLW that do not generate sufficient heat for this to be taken into account in the design of waste storage or disposal facilities.

The major components of ILW are metal items such as nuclear fuel casing and nuclear reactor components, graphite from reactor cores, and sludges from the treatment of radioactive liquid effluents.

High Level Waste (HLW)

Wastes in which the temperature may rise significantly as a result of their radioactivity, so this factor has to be taken into account in the design of waste storage or disposal facilities.

Initially HLW comprises nitric acid solutions containing the waste products of reprocessing spent nuclear fuels.



Monitoring of traces of radioactivity in decommissioning rubble waste

How is radioactive waste produced?

As a pioneer in the development and use of nuclear technology, the UK has accumulated a substantial legacy of radioactive waste from various civil and defence programmes. Waste continues to be produced where radioactive materials are used. The nuclear power industry is the source of most radioactive waste in the UK. This includes waste from:

- Manufacture of nuclear fuel;
- Nuclear power stations;
- Reprocessing of spent nuclear fuel;
- Research and development programmes.

The manufacture of nuclear fuels (fuel fabrication and uranium enrichment) produces low and very low level uranium contaminated radioactive waste.



Assembling nuclear fuel

The UK has ten operating nuclear power stations, and these generate about a fifth of the UK's electricity supply. Nine others have stopped producing electricity. They are now being dismantled and their spent nuclear fuel removed for reprocessing, but so far only relatively small amounts of mainly LLW have been removed from the stations.

Much of the waste is from reprocessing spent nuclear fuels. Reprocessing now only takes place at Sellafield in Cumbria, where spent fuel from most of the UK's power stations, together with spent fuel from overseas reactors, undergoes chemical processes to recover uranium and plutonium.

Nearly all of the waste from research and development (R&D) into nuclear energy is a legacy of Government-funded programmes stretching back to the 1940s.

Sources outside the nuclear power industry that contribute to radioactive waste in the UK include:

- Defence activities;
- Medical and industrial sources.

The main sources of defence waste are nuclear weapons production and operation of the nuclear-powered UK fleet of submarines. Smaller quantities arise from general use of radioactive materials within the armed forces and at defence establishments.

The remaining waste results from the use of radioactivity in medical diagnosis and treatment, and in industrial applications including sterilisation of medical equipment and food, and non-destructive testing of materials (for integrity, thickness, density).

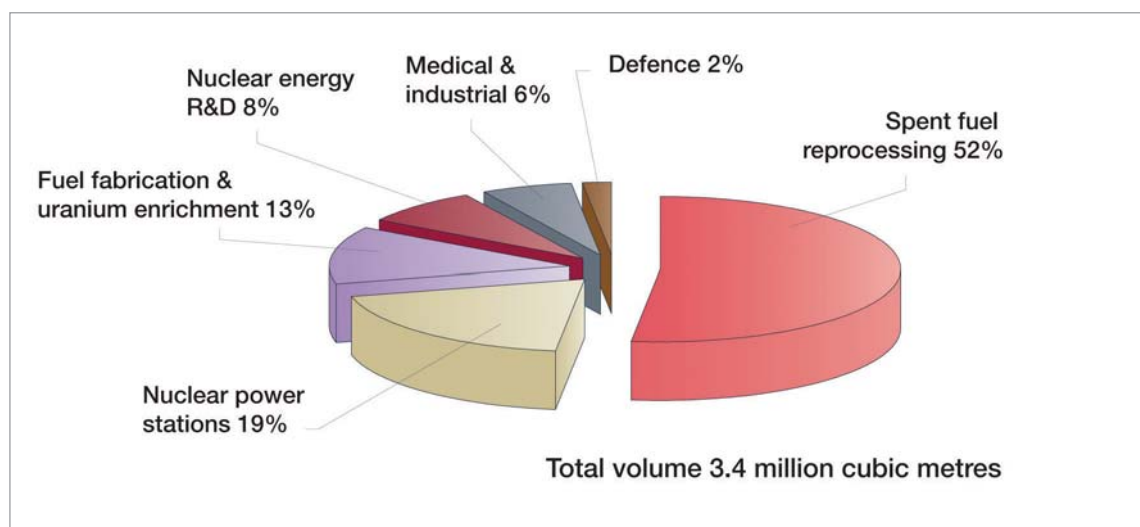

Waste volumes from each activity from existing facilities

Where is radioactive waste produced?

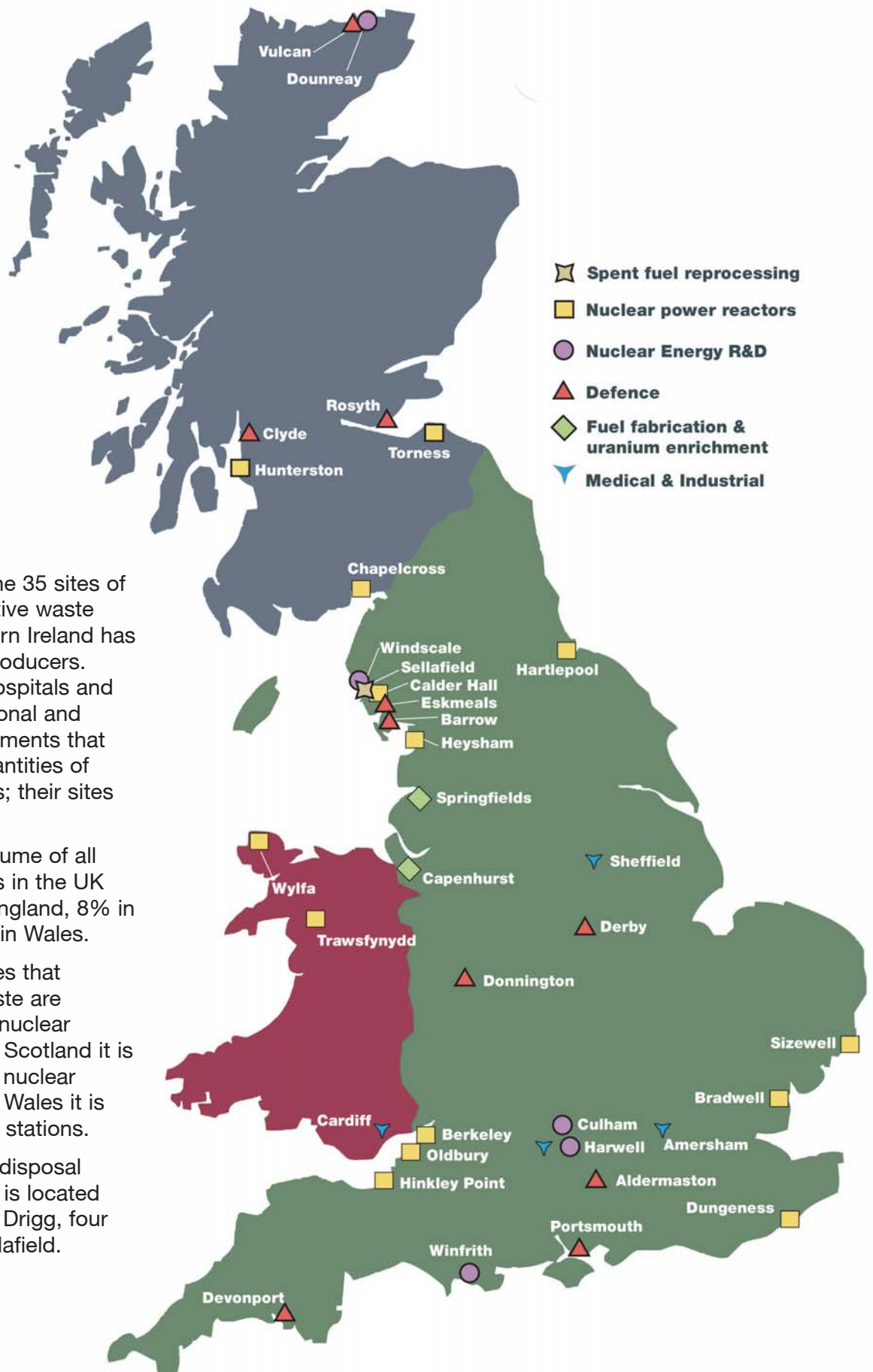

The map shows the 35 sites of the major radioactive waste producers. Northern Ireland has no major waste producers. There are many hospitals and industrial, educational and research establishments that produce small quantities of radioactive wastes; their sites are not shown.

About 89% by volume of all radioactive wastes in the UK are produced in England, 8% in Scotland and 3% in Wales.

In England the sites that produce most waste are Sellafield and the nuclear power stations. In Scotland it is Dounreay and the nuclear power stations. In Wales it is the nuclear power stations.

The national LLW disposal facility, the LLWR, is located near the village of Drigg, four miles south of Sellafield.

How much radioactive waste is there?

The total volume of radioactive waste that exists today or is forecast over the next century or so from existing facilities is about 3.4 million cubic metres. This volume would fill the new Wembley stadium about three times over. The equivalent weight is 3.9 million tonnes. A further 1 million cubic metres of radioactive waste has already been disposed.

Although 3.4 million cubic metres is a large volume of waste, it is only a small part of the waste the UK produces. About 500 million cubic metres of waste are produced in the UK every year, which includes about 5 million cubic metres of hazardous waste.

Over 95% (over 3.2 million cubic metres) of the radioactive waste total has already been produced. Some has been processed, and is being held in stores, but most of it is contained within existing nuclear reactors and other nuclear facilities and will not be processed until these are shut down and dismantled. This waste is the legacy of past and current civil and military nuclear programmes.

Less than 5% (about 150,000 cubic metres) of the radioactive waste total has yet to be produced. This waste is that forecast from the future planned operations of the existing nuclear power industry, from ongoing defence programmes and from the continued use of radioactivity for medical and industrial purposes. The assumptions supporting the forecast future waste volume are shown in the box opposite. Should these assumptions change, which they might for technical, commercial or policy reasons, then the forecast volume would change. Should the use of radioactive materials stop tomorrow then this waste would not be produced.

The waste inventory does not include all radioactively contaminated land. This is because much contaminated land has yet to be well characterised, and so the quantity of radioactive waste resulting from its remediation is uncertain. The total volume of such radioactive waste could add significantly to the figure of 3.4 million cubic metres.

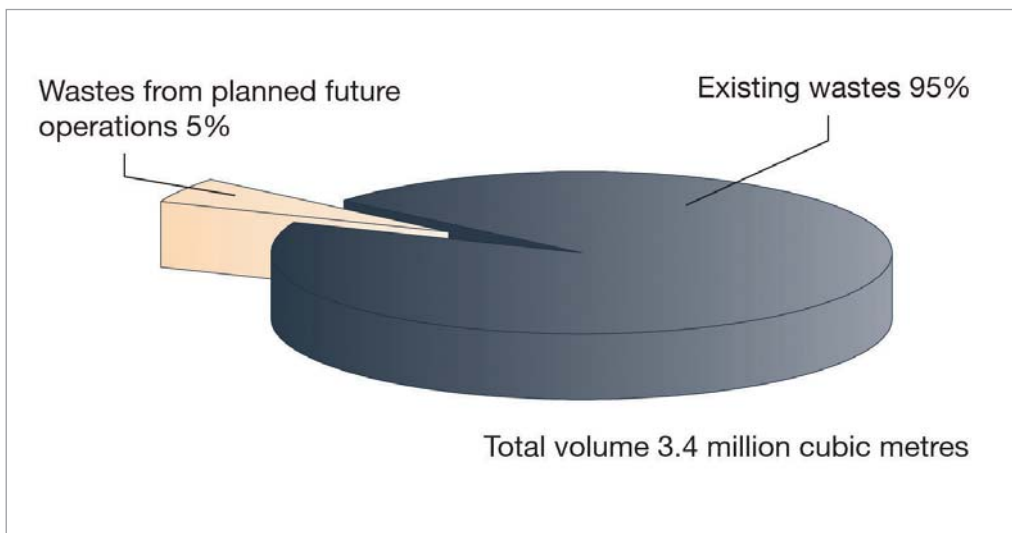

Total waste volumes



Before Dismantling Containers of LLW for the LLWR Facility demolition

Above is a sequence illustrating nuclear facility dismantling and demolition

Assumptions for future waste production as at 1 April 2007

Nuclear power stations

- Remaining operational power stations shut down over the period from 2008 to 2035
- No new nuclear power stations are constructed
- Magnox and AGR structures left on site for about 100 years before final site clearance

Spent fuel reprocessing

- Fuel reprocessing continues until financial year 2012/13

Nuclear energy R&D

- Joint European Torus fusion experiment shut down in 2010

Defence

- A continuing nuclear defence capability (waste estimated up to 2040)
- A continuing nuclear-powered submarine programme (waste estimated up to 2100)

Medical and industrial sources

- The uses of radioactivity continue as today (waste estimated up to 2040)

About 93% (about 3.2 million cubic metres) of radioactive waste falls into the LLW category. Of this volume, about 2.6 million cubic metres are from the dismantling and demolition of nuclear facilities and the clearance of contaminated ground at nuclear sites. About 7% (about 240,000 cubic metres) of radioactive waste is in the ILW category, and less than 0.1% (1,100 cubic metres) is in the HLW category.

Although the volume of HLW is relatively small, it contains about 95% of all radioactivity in radioactive wastes. LLW contains less than 0.01% of the total radioactivity. These percentage values will change gradually over future time as radioactivity decays.



Demolition of Calder Hall towers

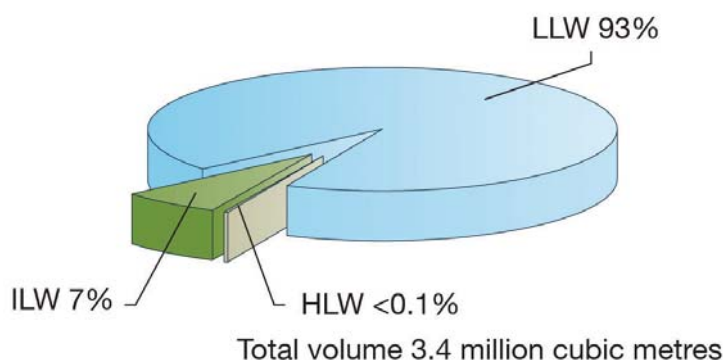

	Total, cubic metres
LLW	3,200,000
ILW	240,000
HLW	1,100
Total	3,400,000

Total volume by waste type

How is radioactive waste dealt with?

The way of dealing with radioactive waste depends to a large extent on how radioactive it is. Thus:

- Most LLW is sent to the LLWR near Drigg in Cumbria or in certain cases to specific landfill sites soon after it is produced;
- ILW is stored in tanks, vaults and drums, with most waste requiring concrete to shield operators from the radiation. Some ILW is being cemented as it arises;
- HLW is stored as liquid in water-cooled, stainless steel tanks or as glass blocks, and needs thick concrete walls to shield operators from the high radiation.

Many radioactive wastes are treated in some way soon after they arise to reduce their volume and so minimise the requirements for storage. Techniques include compaction and incineration (for solid wastes)

and evaporation and filtration (for liquid wastes). Other radioactive wastes are stored untreated.

A particular concern and priority is untreated historic wastes, largely created in the 1940s, 50s and 60s, held in old facilities. Records may be incomplete, meaning that the exact contents of these facilities are uncertain. Some wastes are corroding, and so are potentially mobile. Plans are being made to reduce the hazard posed by these wastes by retrieving, treating and packaging them, although this will take many years.

In time, most radioactive wastes will be packaged. This immobilises the radioactivity, and so reduces the hazard the waste presents compared to its untreated or partly treated form. The process of packaging converts the waste into a solid, stable passively safe form, within high integrity stainless steel or concrete containers.



Drums of LLW after supercompaction



Old nuclear fuel storage pond

LLW

Since 1959 about 1 million cubic metres of LLW from the nuclear power industry, hospitals, research establishments and the defence programmes have been sent to the LLWR.

Up to 1995 about 800,000 cubic metres of waste has been disposed by tipping into trenches that have been capped off.

Now, suitable LLW is supercompacted to minimise its volume. In this process drums or boxes of waste are compacted under high pressure of up to 2,000 tonnes per square metre. The waste is placed in large metal containers, similar to shipping containers. These are then filled with cement and placed in concrete-lined vaults at the LLWR. To date about 8,300 containers have been produced. The total vault space occupied by LLW is about 200,000 cubic metres. Until the vaults are capped off with an engineered cover, the waste is regarded as stored.

About 34,000 cubic metres of LLW disposed in the past at Dounreay are to be retrieved, packaged and consigned to a planned new site LLW disposal facility.

Some wastes with very low activity are routinely sent to specific landfill sites for disposal.

ILW

All ILW has been stored since it was created, except for a small amount disposed of at sea before 1983.

For most ILW, packaging consists of immobilisation in cement-based materials within 500 litre stainless steel drums. Large items are packaged in higher capacity stainless steel or concrete boxes.

Wastes may first be treated to reduce their water content to an optimum level for packaging. Certain materials and small items of equipment can be supercompacted, while other solid wastes are cut up to reduce their size.

There are a number of ILW packaging plants operating at Sellafield. These plants are packaging a variety of solid and sludge wastes from spent fuel reprocessing. ILW packaging plants are also operating at Dounreay, Harwell, Trawsfynydd, Windscale and Winfrith. Further packaging plants are being built and planned.

To date about 21,000 cubic metres of ILW have been packaged, producing about 40,000 packages that are held in modern engineered stores. The NDA has defined standards and specifications for packages, and advises the waste producers on the packaging of ILW.

HLW

At Sellafield high level liquid waste is being incorporated into borosilicate glass, using a process called vitrification. The waste is heated to dryness leaving a fine powder, which is mixed with crushed glass in a furnace to produce a molten product incorporating the waste. This is then poured into stainless steel canisters, which hold approximately 150 litres, and a stainless steel lid is welded on.

Fresh waste from reprocessing is being blended with existing stored liquid waste and vitrified to a programme that maintains liquid waste stock levels within a specification issued by the Health and Safety Executive.

To date nearly 650 cubic metres of vitrified HLW have been produced, and the resulting 4,300 canisters placed in a modern, engineered air-cooled store.

The UK policy is for vitrified HLW to be stored for at least 50 years before disposal.



Store for packaged HLW canisters

What is the long-term management solution?

Present UK Government policy for the long-term management of radioactive waste can be summarised as follows:

- Dispose of suitable LLW in near-surface facilities;
- Dispose of the relatively small volume of LLW not suitable for near-surface disposal in geological disposal facilities along with all ILW and HLW.

As explained previously, methods for disposing of LLW in near-surface facilities already exist. However, the potential capacity of the LLWR is well below the forecast volume of LLW that must be dealt with in the future, and there is a diminishing availability of landfill sites for the lower activity LLW.



Stacking disposal containers at the LLWR

No facilities for disposing of LLW not suitable for near-surface disposal, ILW and HLW have been developed - these wastes are currently stored.

In 2001 the Managing Radioactive Waste Safely (MRWS) programme was initiated by the UK Government and the Devolved Administrations to take a fresh look at management policy of the UK's higher activity wastes that include LLW not suitable for near-surface disposal, ILW and HLW¹.

¹ The MRWS programme takes into consideration some radioactive materials that are not classified as wastes in the UK (and thus are excluded from this inventory). These materials include uranium, plutonium and spent nuclear fuel associated with civil nuclear activities. They have potential value: uranium and plutonium can be used to make nuclear fuel, and spent nuclear fuel can be reprocessed to recover uranium and plutonium for reuse. However, some or all of these materials might be declared surplus to requirements in the future. If so, they would need to be managed as higher activity wastes, and packaged in a way suitable for geological disposal.

It was for these reasons that the UK Government and the Devolved Administrations carried out a review of solid LLW policy. In 2007 a new policy was announced that sets out a more flexible approach for managing solid LLW in the long-term. UK-wide strategies for managing LLW from the nuclear industry and from the non-nuclear sector will be developed in conjunction with the NDA. This includes at what point in the future a replacement (or replacements) for the LLWR might be required and planned, and the extent to which other disposal options might be employed to accommodate the wide range in make up and radioactivity of LLW.



LLW Repository site

An independent Committee on Radioactive Waste Management (CoRWM) was appointed to make recommendations for the long-term management of these wastes that would protect the public and the environment, and inspire public confidence. The challenge in managing these wastes is to isolate their radioactivity from people and the environment for thousands of years.

CoRWM reported in 2006 with a package of recommendations including geological disposal, preceded by safe and secure interim storage. The UK Government has accepted that secure interim storage is essential, and has consulted on a framework for implementing geological disposal.

In principle, the UK Government sees no case for having separate facilities for ILW and HLW if one facility can be developed to provide suitable, safe containment for the waste inventory. There is no reason why this should not be technically possible, although the final decision would be made in the light of site specific environmental, safety and security assessments, the latest technical and scientific information, and international best practice.

The UK Government is looking to use an approach based on voluntarism and partnership with local communities, coupled with the use of appropriate site screening and assessment criteria as the basis for siting a geological disposal facility. Overseas

experience suggests that such an approach is likely to be an effective way of addressing the concerns of communities about hosting such a facility.

The UK Government has invited communities to express an interest in taking part in the process that will ultimately provide a site for a geological disposal facility. The NDA is the implementing organisation, responsible for planning and delivering the geological disposal facility and, as part of this process, will engage with communities and other stakeholders.

The NDA and its agents will have the responsibility for securing the necessary regulatory and planning permissions involving the host community and planning authorities as necessary.

All radioactive wastes without a disposal route currently available will be stored in a safe and secure manner until a suitable disposal facility becomes available.

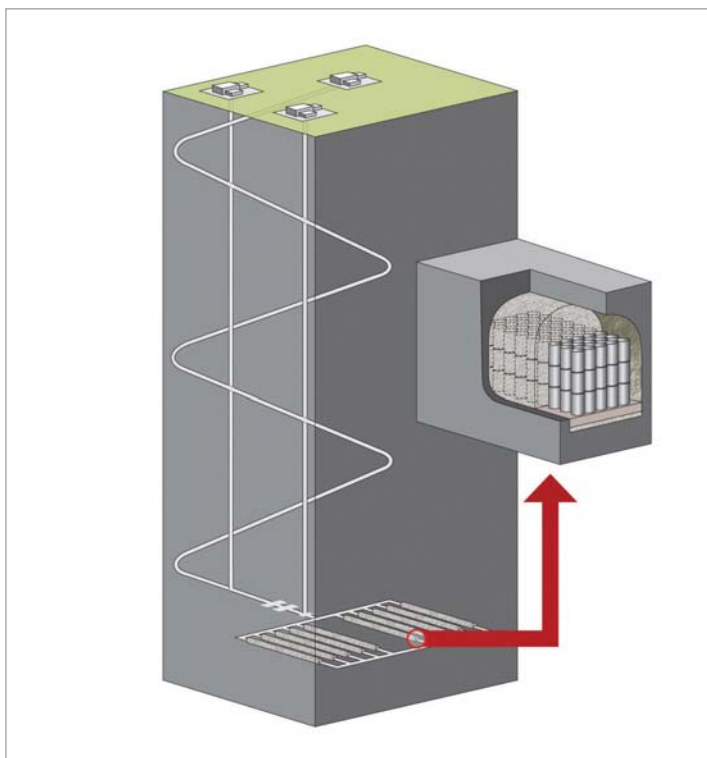

An option for geological disposal of ILW

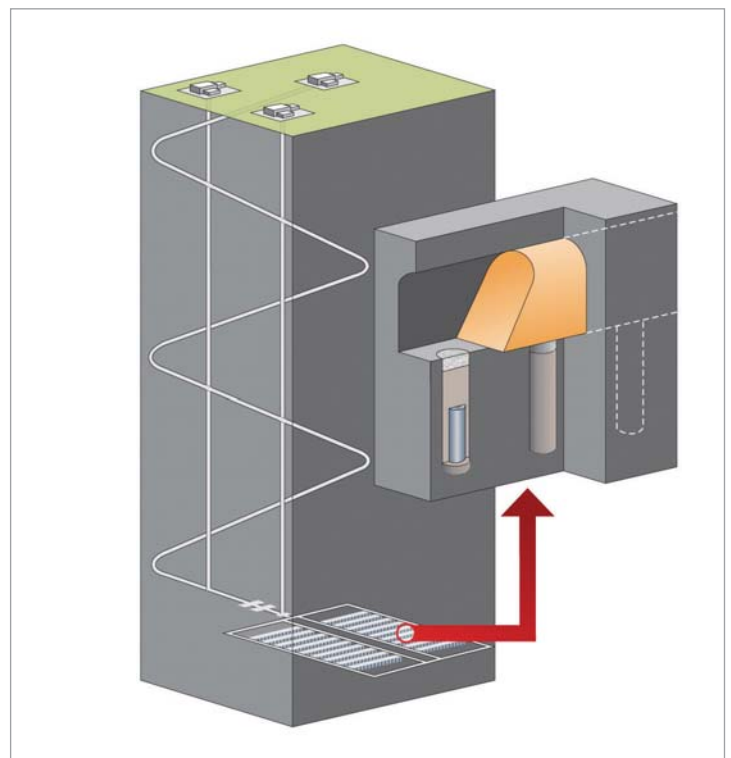

An option for geological disposal of HLW



Certificate No. 4002929 Certificate No. 4002929/A

As well as this report there are a further four reports for the 2007 UK Radioactive Waste Inventory:

- The main report for the 2007 Inventory;
- A summary of Information for International Reporting;
- A review of the processes contributing to radioactive wastes in the UK;
- Information on radioactive materials not included in the 2007 Inventory is presented in a separate report.

These reports are available in both printed and electronic format. Detailed information on the volumes, radioactive, physical and chemical content of the 1269 separate radioactive waste streams reported in the 2007 Inventory is only available in electronic format.

The above reports and detailed information can be obtained on CD-ROM from the NDA (see address below) or via the UK Radioactive Waste Inventory website www.nda.gov.uk/ukinventory

Nuclear Decommissioning Authority
Information Access Manager
Herdus House
Westlakes Science & Technology Park
Moor Row
Cumbria
CA24 3HU

T +44 (0) 1925 802077
foi@nda.gov.uk

ISBN 978-1-84029-387-6

Front cover images: top left - Wylfa site, top right - Low Level Waste Repository, bottom left - Harwell site, bottom right - Hunterston A site